

Našumo siekis

Saulius Gražulis

Vilnius, 2020

Vilniaus universitetas, Matematikos ir informatikos fakultetas
Informatikos institutas



Ši skaidrių rinkinį galima kopijuoti, kaip nurodyta [Creative Commons Attribution-ShareAlike 4.0 International](https://creativecommons.org/licenses/by-sa/4.0/) licenzijoje



Besser als viel Speicher ist noch mehr Speicher...

(Geriau negu daug atminties yra dar daugiau atminties...)

Vokiškas anekdotas

- Puslapiavimas (paging)
- Segmentavimas (segmentation)

Atminties valdymas 64 bitų režime

x86, 86_64 CPU

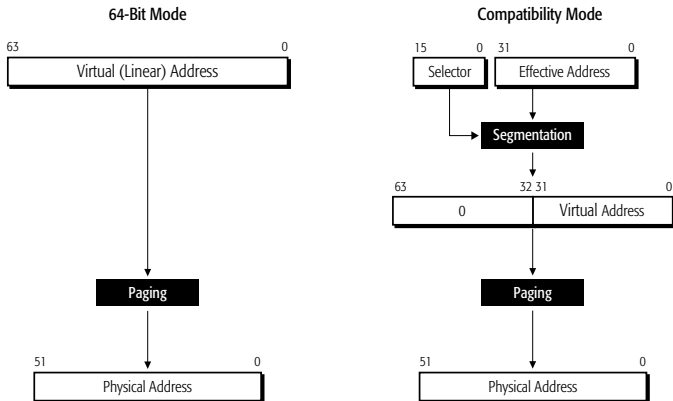

(AMD 2017)

Virtuali Atmintis. Segmentai

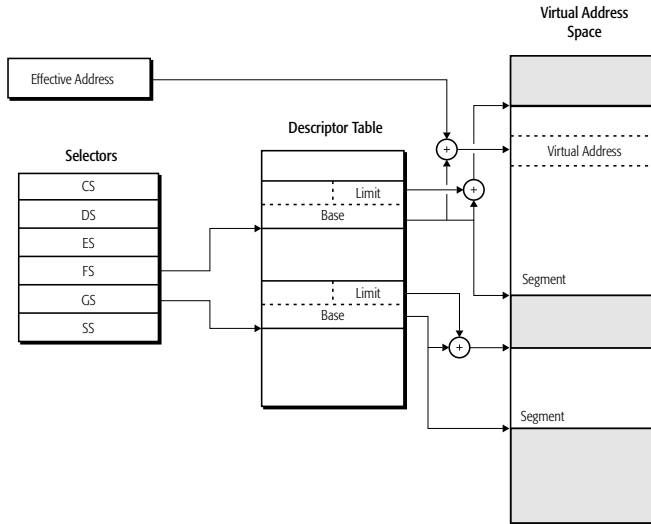

(Жмакин 2006; AMD 2012)

Virtuali Atmintis. Segmentai

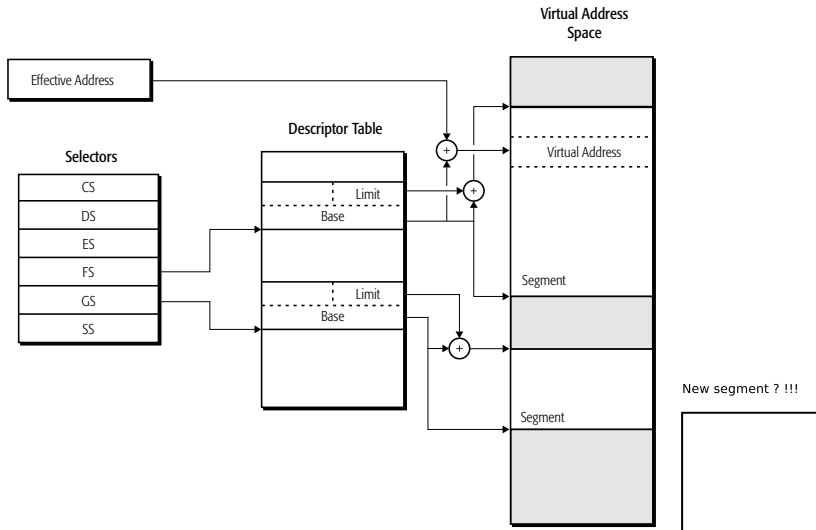

(Жмакин 2006; AMD 2012)

Virtuali atmintis. Puslapiavimas

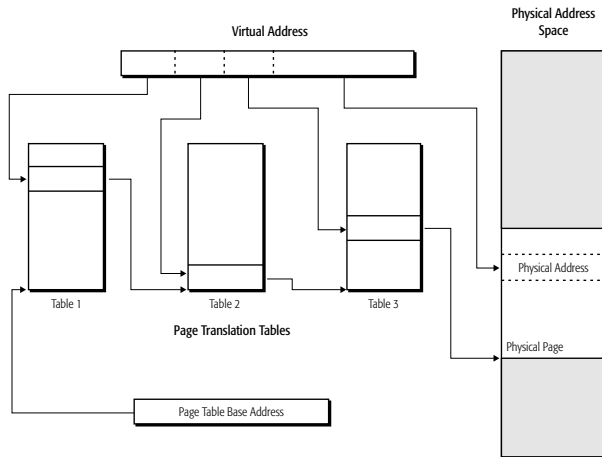

(AMD 2012)

Virtuali atmintis. Puslapiavimas

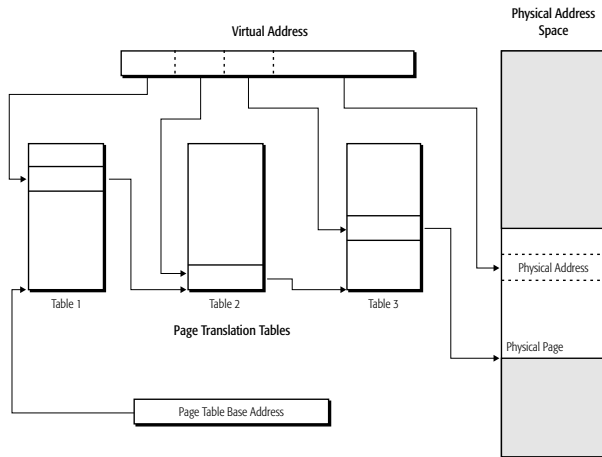

Translation-Lookaside Buffer (TLB) \Leftrightarrow page-translation cache
(AMD 2012)

Virtuali atmintis. Puslapiavimas

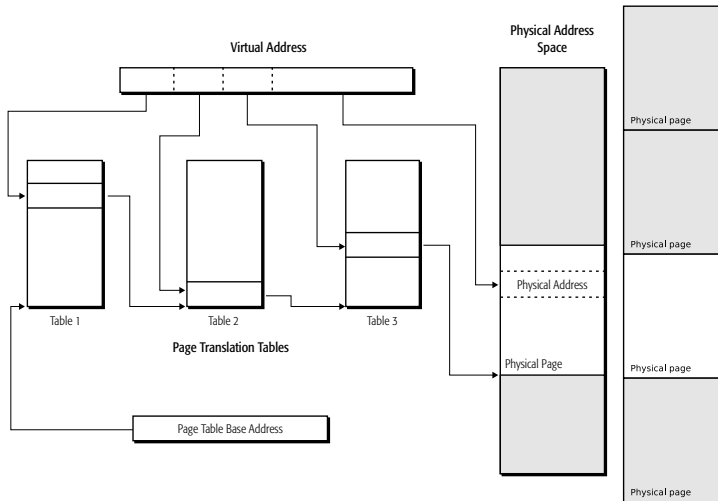

Translation-Lookaside Buffer (TLB) \Leftrightarrow page-translation cache
(AMD 2012)

Virtuali atmintis. Puslapiavimas

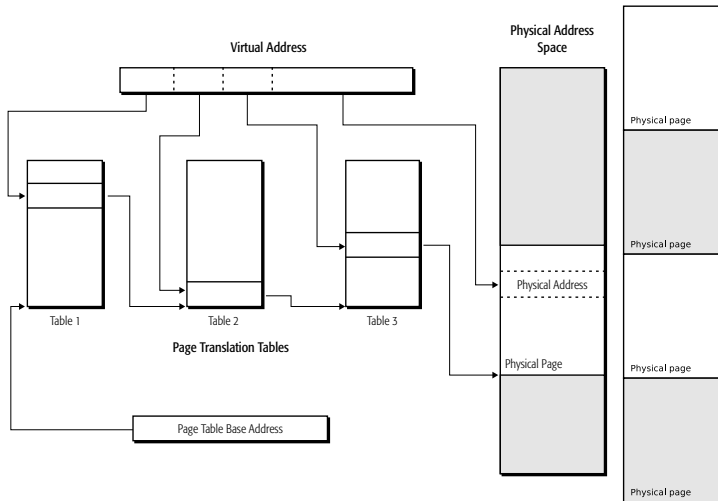

Translation-Lookaside Buffer (TLB) \Leftrightarrow page-translation cache
(AMD 2012)

Virtuali atmintis. Skirtingi puslapių dydžiai

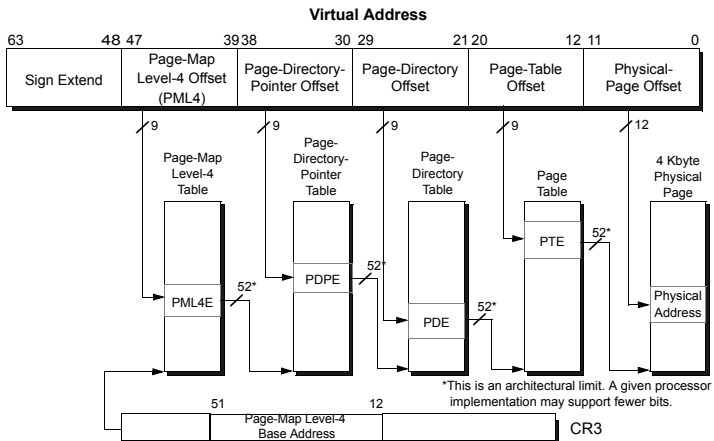

Figure 5-17. 4-Kbyte Page Translation—Long Mode

Virtuali atmintis. Skirtingi puslapių dydžiai

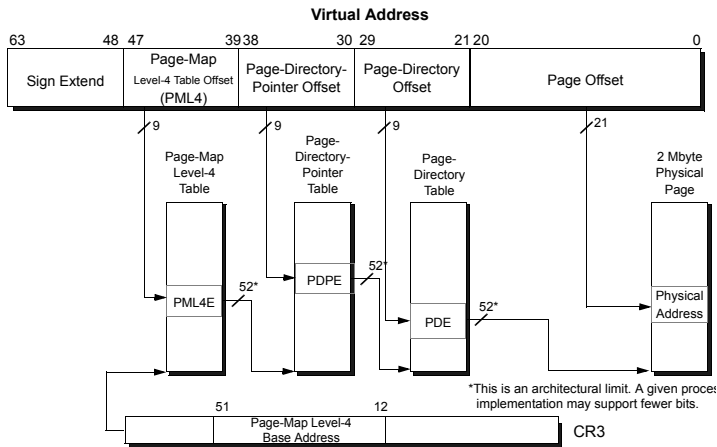

Figure 5-22. 2-Mbyte Page Translation—Long Mode

Virtuali atmintis. Skirtingi puslapių dydžiai

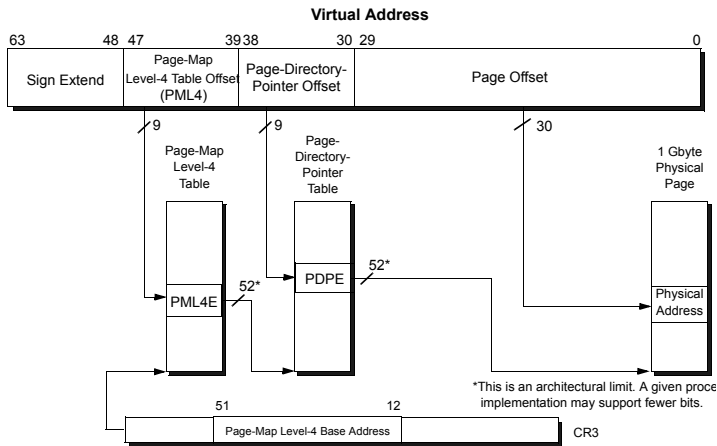

Figure 5-26. 1-Gbyte Page Translation—Long Mode

Virtuali atmintis. Puslapių atributai

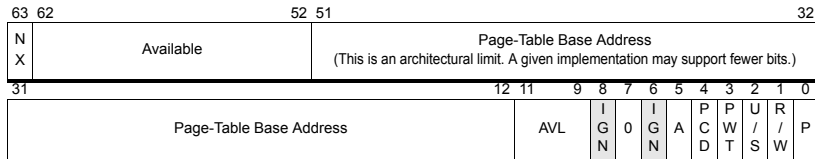

Figure 5-20. 4-Kbyte PDE—Long Mode

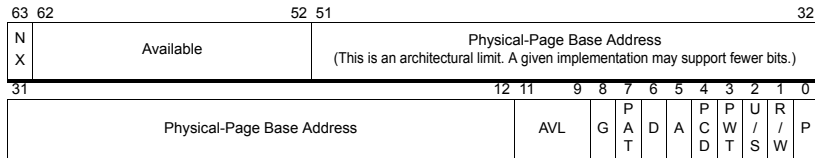
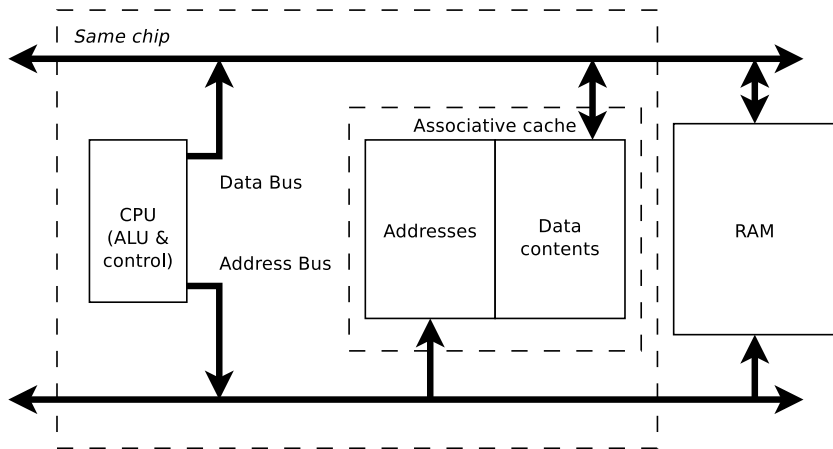

Figure 5-21. 4-Kbyte PTE—Long Mode

(AMD 2012)

Spartinanti atmintis

Asociatyvinė atmintis



(Жмакин 2006)

Spartinančios atminties atnaujinimas

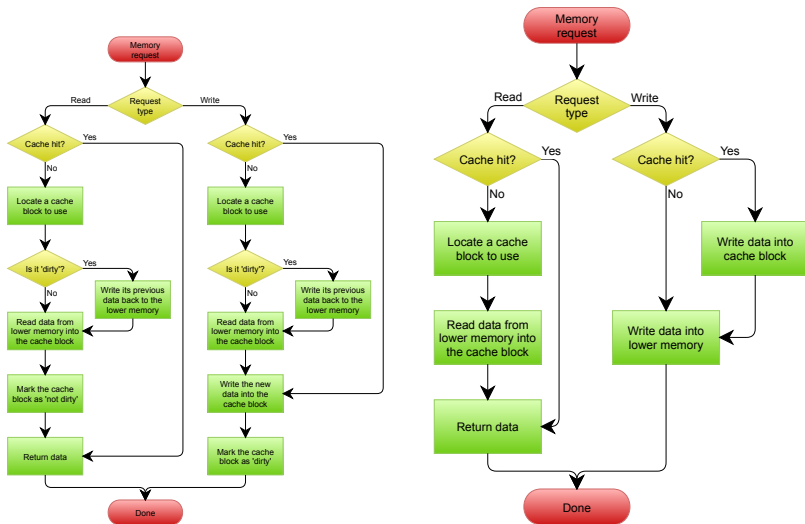

Spartinančios atminties neprieštaringumas

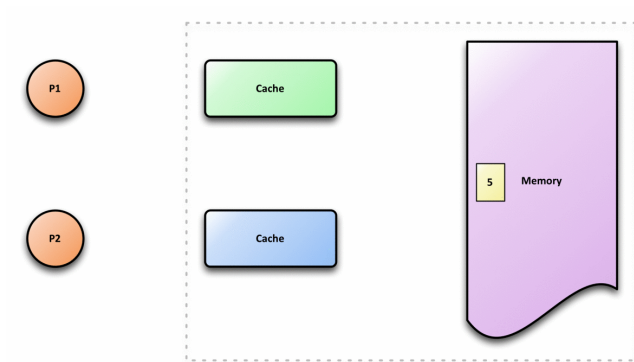

By M3tainfo - Own work, CC BY-SA 4.0

Spartinančios atminties neprieštaringumas

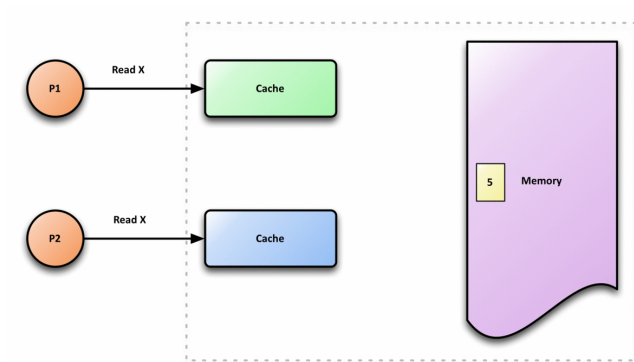

By M3tainfo - Own work, CC BY-SA 4.0

Spartinančios atminties neprieštaringumas

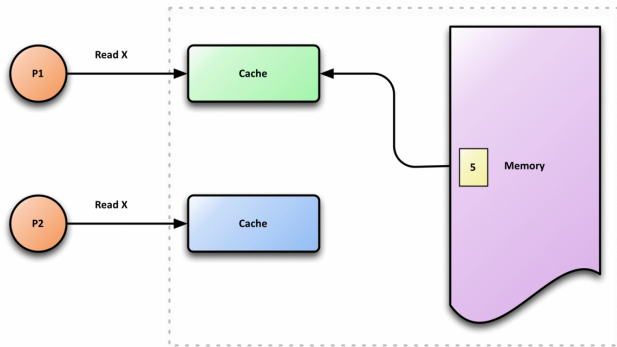

By M3tainfo - Own work, CC BY-SA 4.0

Spartinančios atminties neprieštaringumas

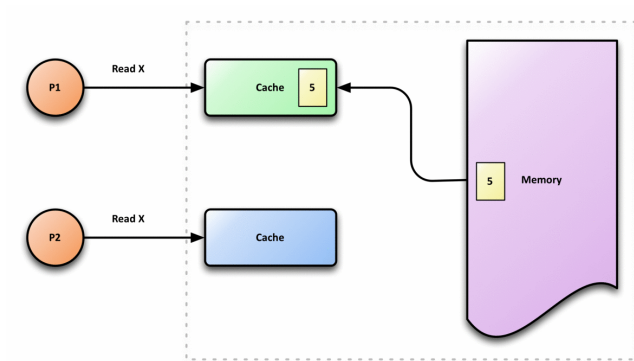

By M3tainfo - Own work, CC BY-SA 4.0

Spartinančios atminties neprieštaringumas

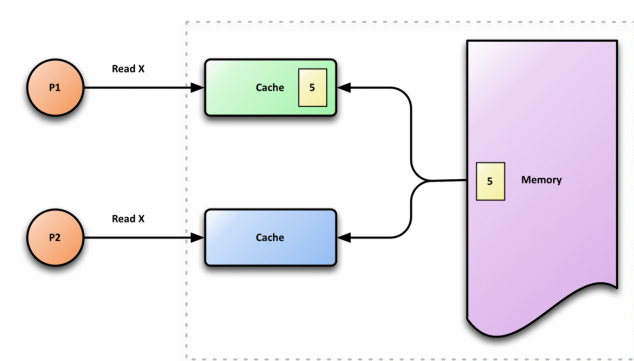

By M3tainfo - Own work, CC BY-SA 4.0

Spartinančios atminties neprieštaringumas

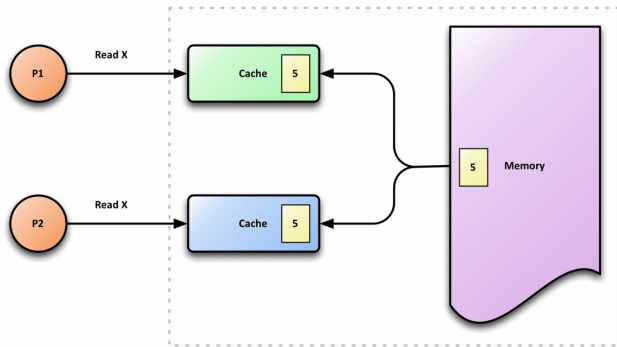

By M3tainfo - Own work, CC BY-SA 4.0

Spartinančios atminties neprieštaringumas

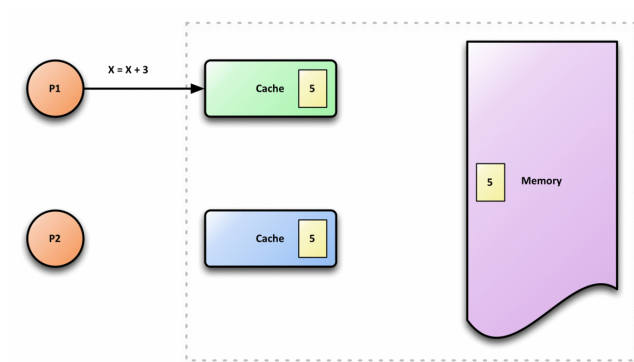

By M3tainfo - Own work, CC BY-SA 4.0

Spartinančios atminties neprieštaringumas

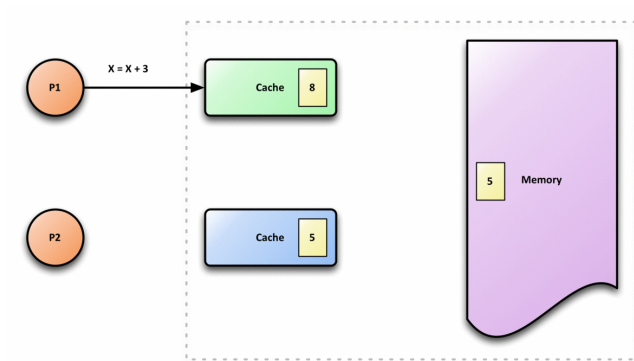

By M3tainfo - Own work, CC BY-SA 4.0

Spartinančios atminties neprieštaringumas

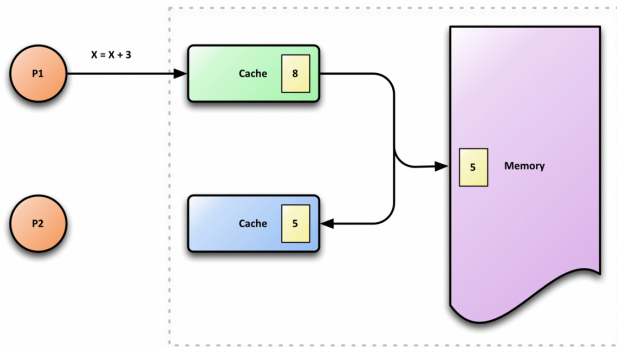

By M3tainfo - Own work, CC BY-SA 4.0

Spartinančios atminties neprieštaringumas

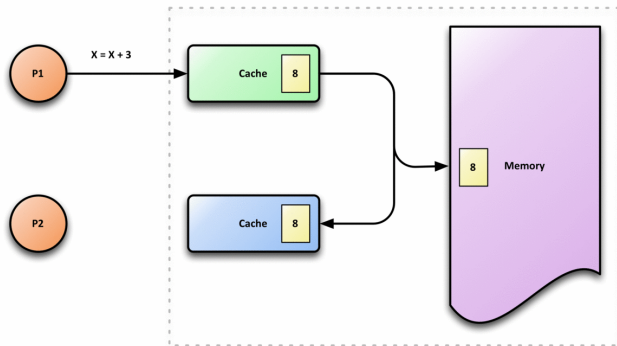

By M3tainfo - Own work, CC BY-SA 4.0

Spartinančios atminties neprieštaringumas

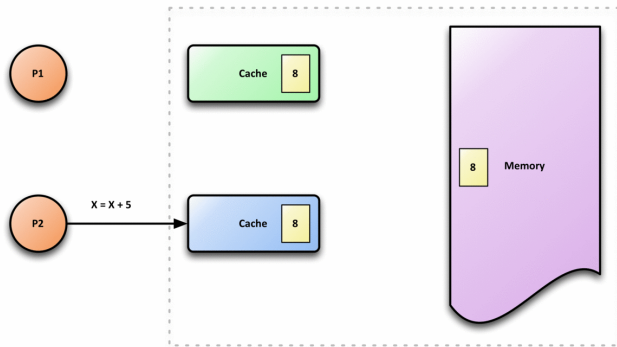

By M3tainfo - Own work, CC BY-SA 4.0

Spartinančios atminties neprieštaringumas

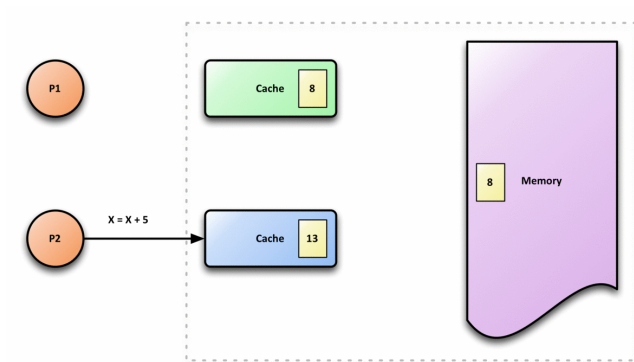

By M3tainfo - Own work, CC BY-SA 4.0

Spartinančios atminties neprieštaringumas

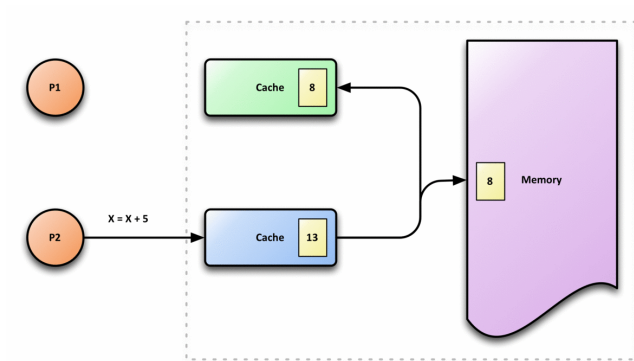

By M3tainfo - Own work, CC BY-SA 4.0

Spartinančios atminties neprieštaringumas

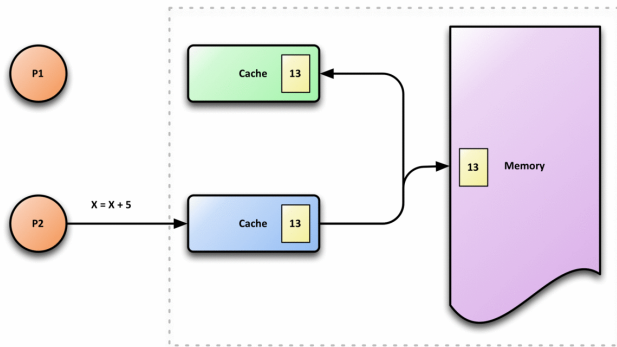

By M3tainfo - Own work, CC BY-SA 4.0

Spartinančios atminties neprieštaringumas

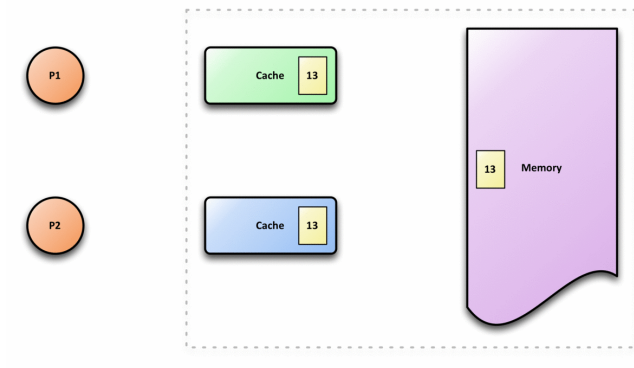

By M3tainfo - Own work, CC BY-SA 4.0

EkspONENTINIS SKAIČIŲ UŽRAŠYMAS

$$602\underbrace{00\dots0}_{21 \text{ kartų}} = 6.02 \times 10^{23}$$

$$\pm d_0.d_1d_2\dots d_{p-1} \times \beta^e = \sum_{i=0}^{p-1} d_i\beta^{-i} \times \beta^e, (0 \leq d_i < \beta)$$

$$\pm d_0.d_1d_2\dots d_{p-1} \times \beta^e = \sum_{i=0}^{p-1} d_i\beta^{-i} \times \beta^e, (0 \leq d_i < \beta)$$

$$\beta = 2$$

$$0.1 \approx 1.10011001100110011001101 \times 2^{-4}$$

- Mantisė: absoliutus dydis su ženklu
- Eksponentė: skaičius su postūmiu
- „Paslėptas“ bitas

$$0.1 \approx 1.10011001100110011001101 \times 2^{-4}$$

p: 23+1 bitas e: -126 - 127 (8 bitai)

$f = 1.10011001100110011001101$

$e = 127 + (-4) = 123_{10} = 01111011_2$

0 01111011 10011001100110011001101

- AMD (Sept. 2012). *AMD64 Architecture Programmer's Manual, Volume 2: System Programming*. Vol. 2. AMD. URL: http://developer.amd.com/wordpress/media/2012/10/24593%5C_APM%5C_v2.pdf.
- (Dec. 2017). *AMD64 Architecture Programmer's Manual, Volume 1: Application Programming, revision 3.22*. AMD. URL: <https://www.amd.com/system/files/TechDocs/24592.pdf>.
- Жмакин, А. П. (2006). *Архитектура ЭВМ*. БХВ-Петербург. ISBN: 5-94157-719-2.